

Auch jede andere Größe (d1) lieferbar

Standardausführung: KALTVERFORMT
Warmverformung auf Wunsch möglich

*1: Lochmaß kann aus fertigungstechnischen Gründen abweichen.

Biegeradien nach DIN 6935

*2: Zubehör muss gesondert bestellt werden

Größenangaben, wenn nicht anders beschrieben, in mm
Gewichtangaben exkl. Zubehör

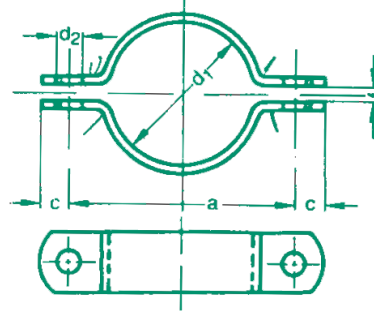

Form A

Alle Angaben bestmöglich ermittelt, ohne Gewähr

d ₁	Anzuwenden bei Nennweite		a* ¹	c	d ₂	f	Flachstahl	Zubehör* ² : Sechskantschrauben	100 Paar = kg					
20	15		57	15	11,5	7	30 x 5	M10 x 30Mu	19					
22			59						20					
25		20							62	21				
27	¾"		66						22					
30			68						23					
34	25	1"	72						24					
38	32		76						26					
43		1¼"	82						27					
45			84						28					
49	40	1½"	88						30					
57	50		104	18	14	9	40 x 6	M12 x 35Mu	54					
61		2"	108						55					
77		2½"	122						60					
89		3"	136						70					
108	100		172						24	18	11	50 x 8	M16 x 45Mu	140
115		4"	178	145										
133		125		196	168									
140			204	180										
159	150			222	200									
169			232	205										
194		175	258	240										
216	200		280	255										
220			284	260										
267		250	342	360										
273		348	390											
324	300	398	445											
356	350		432	30	23	14	60 x 8	M20 x 50Mu	500					
368			444						520					
407		400							498	36	27	18	70 x 10	M24 x 60Mu
419			510						860					
508	500								600					
521			614						1020					
610		600	702						1222					
712	700	830	1380											
813	800	930	1540											
915	900	1030	1720											
1016	1000	1130	1880											